



REVISIONS				
REV	DESCRIPTION	ECO #	DATE	APPROVED
-	INITIAL RELEASE	14-388	11/17/14	T.KUHN

SPECIFICATIONS

MECHANICAL

BODY & NUT _____ **STAINLESS STEEL**
 IAW ASTM-A484 & ASTM-A582,
 ALLOY 303, COND A,
 GOLD PLATED

GASKET _____ **SILICON RUBBER AA-59588,**
 CLASS 2, GRADE 50

MARKING

PART LOOKS LIKE PRODUCT IMAGE ABOVE.
 PART MARKING ORIENTATION AND FORMAT AS SHOWN.
 MARKING TO BE AS LARGE AS POSSIBLE, CLEAR, AND READABLE.
 YYWW = DATE CODE.

IAW WITH HONEYWELL 876808-00

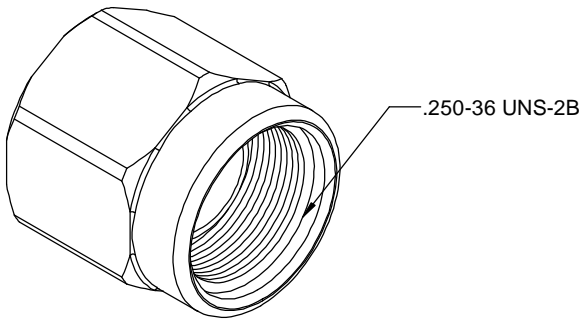
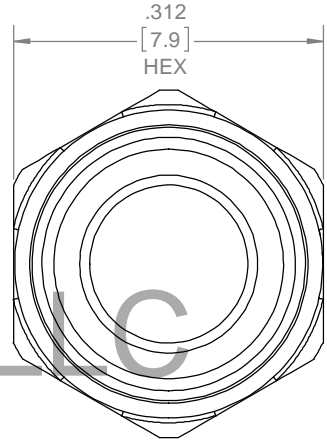
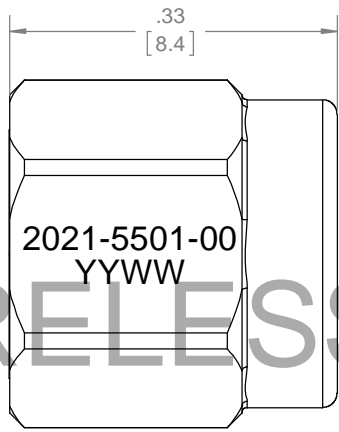

QTY.	PART NUMBER	DESCRIPTION	ITEM NO.
X	2021-5501-00	DUST CAP, SMA-m, CUSTOM	
1	TA-2021-5501-00U	ASSEMBLY, DUST CAP, SMA-m, CUSTOM, UNMARKED	1

DRAWING PRACTICES PER ANSI-Y-14.5 MIL-STD-100 & 1000
 DIMENSIONS ARE IN INCHES AND APPLY BEFORE / AFTER PROCESSING
 SURFACE ROUGHNESS μ INCHES **63**
 FINISH:
 SEE NOTES
 MATERIAL:
 SEE NOTES
 NOTE:
 THIS DRAWING INCORPORATES THIRD ANGLE PROJECTION.

 INTERPRET IAW ANSI Y14.5-1982

UNLESS OTHERWISE SPECIFIED TOLERANCES IN:
 DECIMALS INCH [MM]
 .X" .05" [1.27]
 .XX" .03" [.76]
 .XXX" .010" [.25]
 ANGLES $\pm 0^{\circ}30'$
 REMOVE ALL BURRS/SHARP W/ BREAK / R OF .003" TO .0005" UNLESS OTHERWISE NOTED DIAS CONCENTRIC <.003 T.I.R.
 DO NOT SCALE PRINT

DRAWN DATE
MCCORMICK 11/17/14
 CHECKED DATE
MCCORMICK 11/17/14
 ENG. APPR. DATE
T.KUHN 11/17/14

Phone: 603-222-2256 Fax: 603-222-2259
 150 Dow Street, Manchester, NH 03101
 TITLE

THESE DRAWINGS AND SPECIFICATIONS ARE THE PROPERTY OF XMA CORP. OR OMNI SPECTRA AND SHALL NOT BE REPRODUCED, COPIED NOR USED - IN WHOLE OR IN PART - AS A BASIS FOR THE MANUFACTURE OR SALE OF OTHER ITEMS WITHOUT THE EXPRESS WRITTEN PERMISSION OF XMA CORP.

DUST CAP, SMA-m, CUSTOM			
SIZE	CAGE CODE	DRAWING NUMBER	REV
B	3HT76	2021-5501-00	-
SCALE	PLATED AREA SQ. IN	SHEET 1 OF 1	