

5

4

3

2

1

Precision Wireless POWERED BY **Omni Spectra®**
 外来文件受控章

| REVISIONS | | | | |
|-----------|------------------------------|--------|---------|----------|
| REV | DESCRIPTION | ECO # | DATE | APPROVED |
| C | RELEASED | | 6/7/12 | T.KUHN |
| D | ADDED MARKING; UPDATE FORMAT | 15-233 | 7/28/15 | T.KUHN |
| | | | | |
| | | | | |

SPECIFICATIONS

MECHANICAL

- HOUSING AND COUPLING NUT _____ PASSIVATED STAINLESS STEEL IAW A582, TYPE 303
- GASKET _____ SILICONE RUBBER PER ZZ-R-765, CLASS B, GRADE 70
- RETAINING RING _____ BERYLLIUM COPPER, C17200 COND H, PER ASTM-B194

MARKING

PART LOOKS LIKE PRODUCT IMAGE ABOVE.
 PART MARKING ORIENTATION AND FORMAT AS SHOWN.
 MARKING TO BE AS LARGE AS POSSIBLE, CLEAR, AND READABLE.
 YYWW EQUALS DATE CODE.

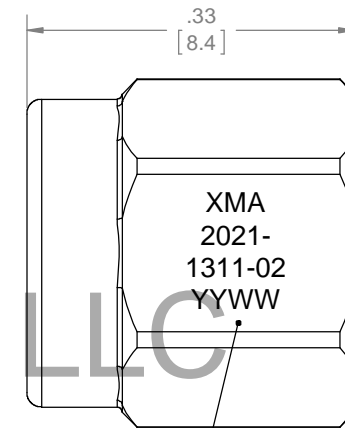
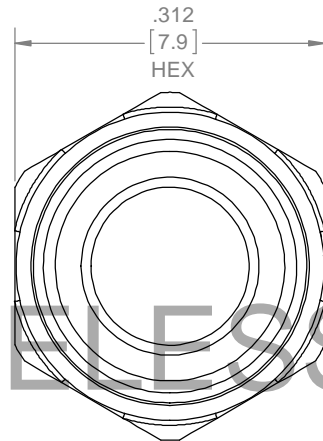

MARKING AREA

PRECISION WIRELESS, LLC

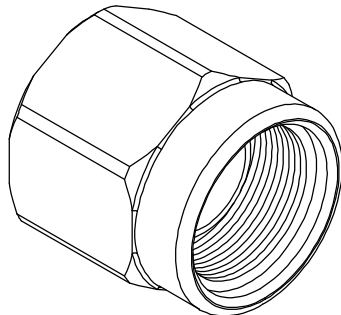

| QTY. | PART NUMBER | DESCRIPTION | ITEM NO. |
|------|------------------|-------------------------------------|----------|
| X | 2021-1311-02 | DUST CAP, SMA-m | |
| 1 | TA-2021-1311-02U | ASSEMBLY, DUST CAP, SMA-m, UNMARKED | 1 |

| | |
|--|----|
| DRAWING PRACTICES PER ANSI-Y-14.5 MIL-STD-100 & 1000 | |
| DIMENSIONS ARE IN INCHES AND APPLY BEFORE / AFTER PROCESSING | |
| SURFACE ROUGHNESS μ INCHES | 63 |
| FINISH: | |
| SEE NOTE | |
| MATERIAL: | |
| SEE NOTE | |
| NOTE: THIS DRAWING INCORPORATES THIRD ANGLE PROJECTION. | |
| | |
| INTERPRET IAW ANSI Y14.5-1982 | |

| | |
|--|-------------|
| UNLESS OTHERWISE SPECIFIED TOLERANCES IN: | |
| DECIMALS | INCH (MM) |
| .X" | .05" [1.27] |
| .XX" | .03" [.76] |
| .XXX" | .010" [.25] |
| ANGLES $\pm 0^{\circ}30'$ | |
| REMOVE ALL BURRS/SHARP W/ BREAK / R OF .003" TO .0005" UNLESS OTHERWISE NOTED DIAS CONCENTRIC <.003 T.I.R. | |
| DO NOT SCALE PRINT | |

| | |
|--|---------|
| DRAWN | DATE |
| T.KUHN | 2/26/09 |
| CHECKED | DATE |
| ENG. APPR. | DATE |
| T.KUHN | 6/7/12 |
| THESE DRAWINGS AND SPECIFICATIONS ARE THE PROPERTY OF XMA CORP. OR OMNI SPECTRA AND SHALL NOT BE REPRODUCED, COPIED NOR USED - IN WHOLE OR IN PART - AS A BASIS FOR THE MANUFACTURE OR SALE OF OTHER ITEMS WITHOUT THE EXPRESS WRITTEN PERMISSION OF XMA CORP. | |

XMA POWERED BY **Omni Spectra®**

Phone: 603-222-2256 Fax: 603-222-2259
 150 Dow Street, Manchester, NH 03101

TITLE
DUST CAP, SMA-m

| | | | |
|-------|--------------------|----------------|-----|
| SIZE | CAGE CODE | DRAWING NUMBER | REV |
| B | 3HT76 | 2021-1311-02 | D |
| SCALE | PLATED AREA SQ. IN | SHEET 1 OF 1 | |

5

4

3

2

1